

Fitting Instructions

OETTINGER A3 Sportback



OETTINGER Front grille for Audi A3 Sportback / Audi A3 (8P) 3 dr. facelift

Order No: OE 804 282 00 (Silver) and OE 804 288 00 (Black)

Note

The OETTINGER Front grille is manufactured from high quality material for an accurate fit and is painted.

General

The OETTINGER Front grille replaces the standard grille and uses the standard mounting points. It is necessary to remove the front bumper from the vehicle to allow fitting.

1. Preparation for assembly

- Jack the vehicle up and make sure that it is secure.
- Remove the front wheels
- Remove the front licence plate.
- Open the bonnet/hood

2. Removing the front bumper

- Remove the Torx screws from the top of the standard grille (illustration 1).
- Release the splash guard from the bottom of the bumper, to do this remove all the Torx screws.
- Remove the upper front wheel arch liners by unscrewing the Torx screws.
- Then release the lower front wheel arch liners, again by removing the Torx screws securing the liners.
- Unscrew 1 Hexagon head screw from inside each wheel well as shown in illustration 2.
- Remove 2 Torx screws either side from the side guide brackets as shown in illustration 3.
- Disconnect the wires from the fog lamps.
- Pull off the hose for the headlamp washers from the reservoir and plug the connector on the reservoir.
- Carefully unclip the bumper from the guide brackets and wing/fender either side and release from the bonnet/hood latch, then pull off the vehicle.

3. Fitting the OETTINGER grille

- Unclip the standard grille from the bumper and remove.
Important: Check that correct side of the grille mesh faces outwards before mounting (see illustration 4)
- Fix both pieces of mesh to the painted OETTINGER grille frame using the screws provided (illustrations 5 and 6).
Note: Do not insert any screws in the upper mesh in the positions marked with an arrow (illustration 5).
Note: Do not trim the mesh left and right of the upper opening, otherwise trim any excess mesh.
- Mount the OETTINGER badge (supplied) and Audi Rings (not incl.) on the upper grille insert (illustration 8).
- Clip the OETTINGER grille insert in the bumper, pushing it firmly in place and fix using the screws supplied (illustration 9 and 10).

4. Remounting the front bumper

- Carefully push the bumper onto the guide brackets and clip it into the wings/fenders. Check the the gaps and fit before fixing in position.
- Mount the bumper in reverse order as described in section 2 and then remount the licence plate.

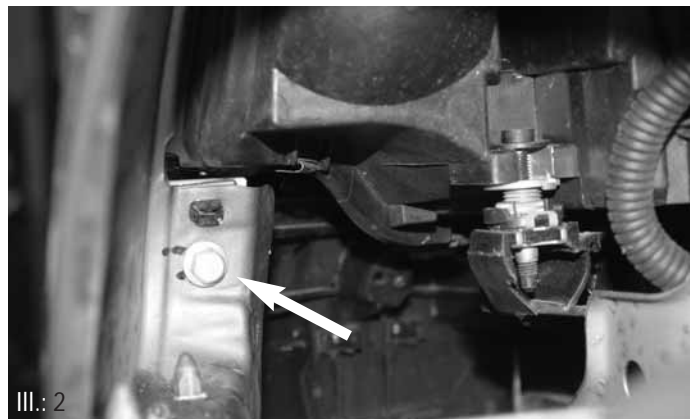
Illustration of the OETTINGER grille for the Audi A3 Sportback / A3 (8P) facelift

Illustration of the OETTINGER grille for the Audi A3 Sportback / Audi A3 (8P) 3 dr. facelift

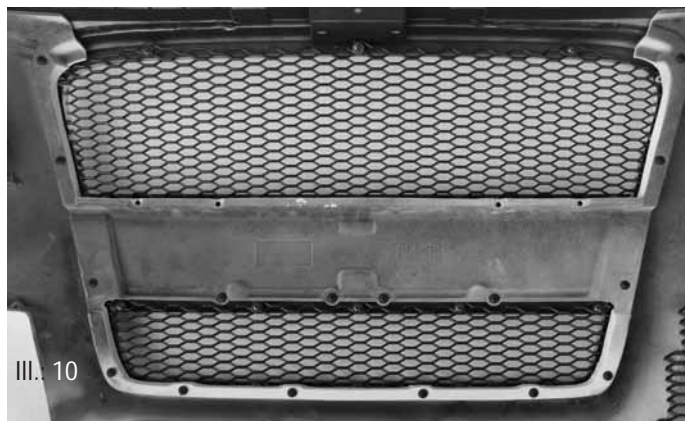
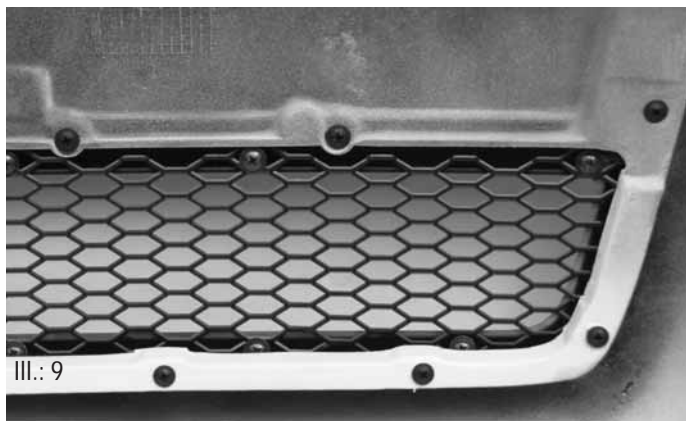
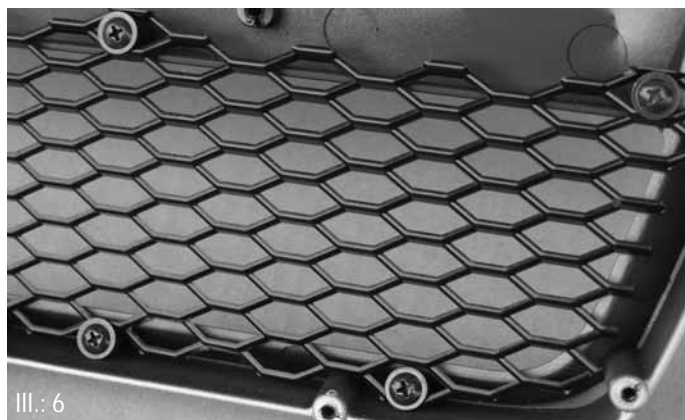
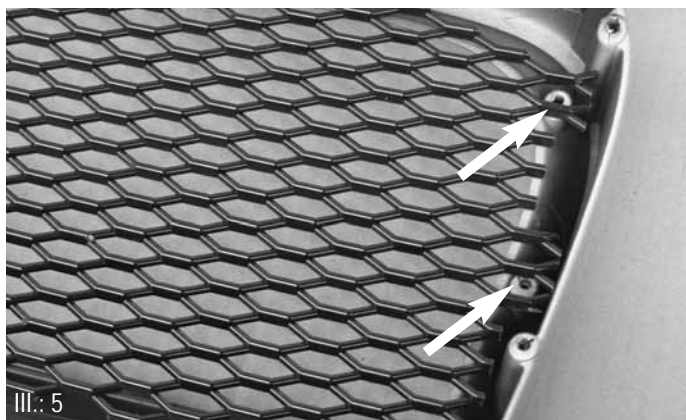
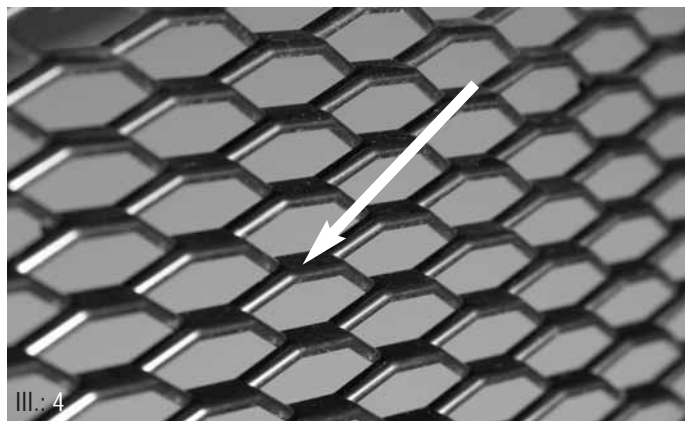


Illustration of the OETTINGER grille for the Audi A3 Sportback / Audi A3 (8P) 3 dr. facelift

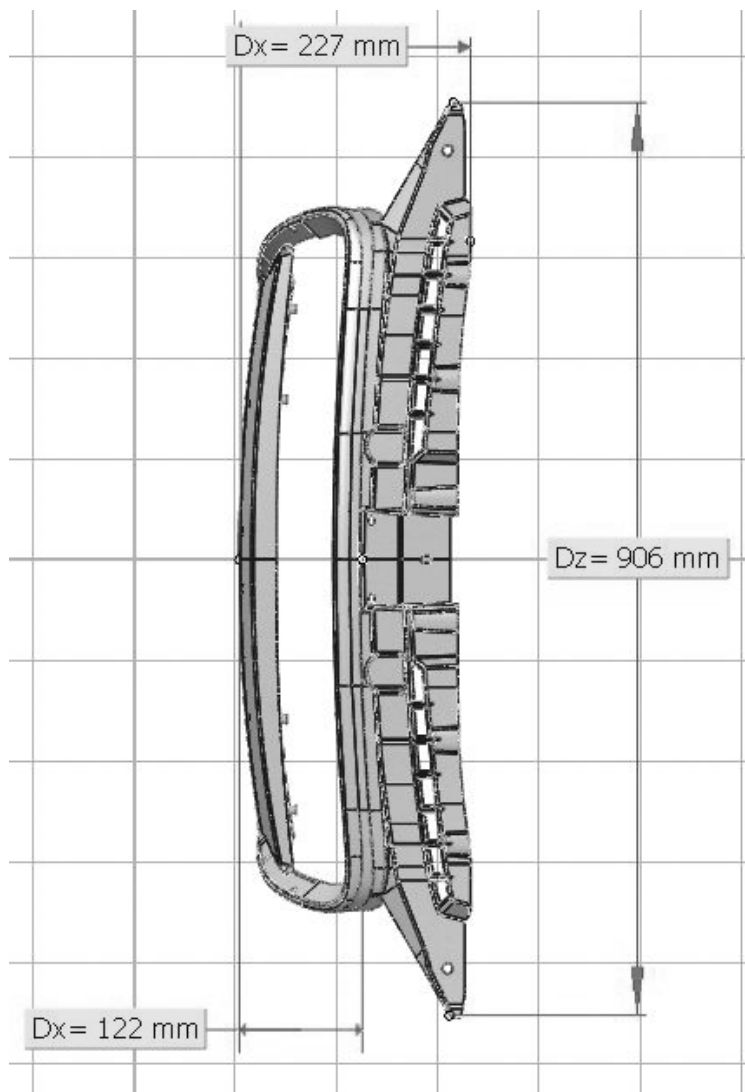
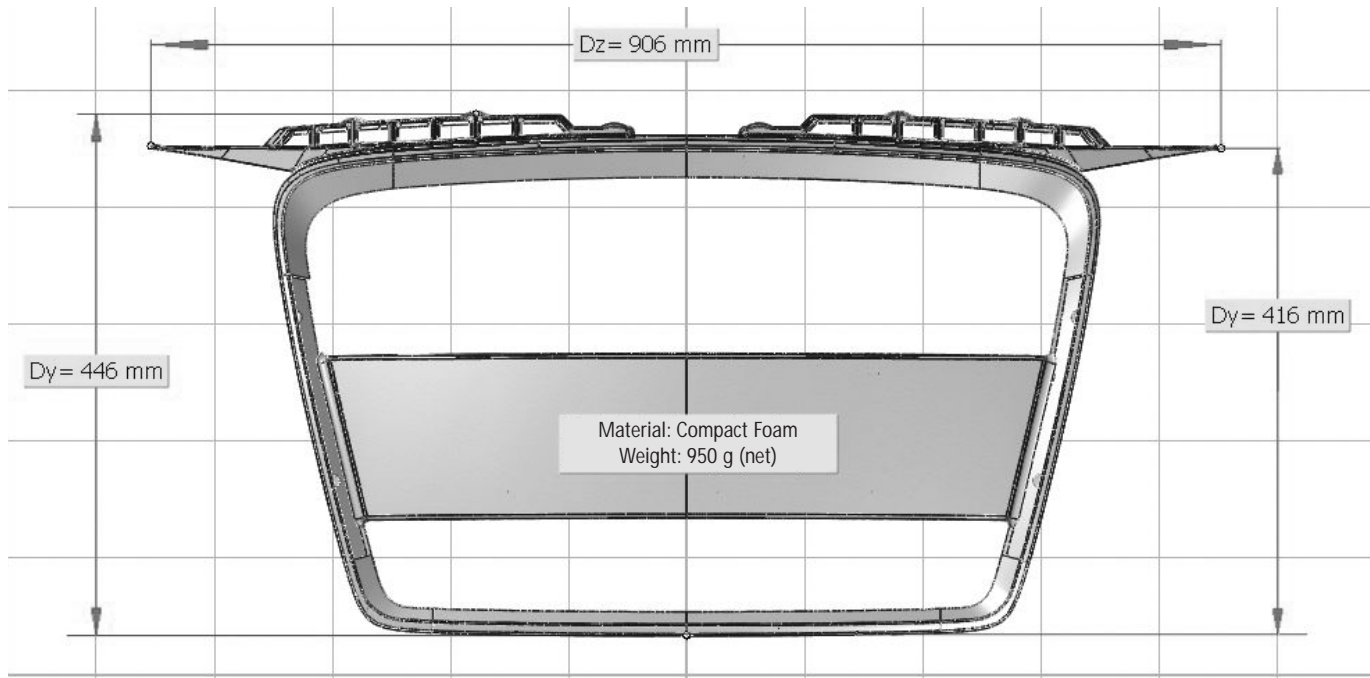


Illustration of the OETTINGER grille for the Audi A3 Sportback / Audi A3 (8P) 3 dr. facelift



OETTINGER Front apron for the Audi A3 Sportback / A3 (8P) 3 dr. facelift

Order No: OE 804 283 00

Note

The OETTINGER Front apron is manufactured from high quality material for an accurate fit and is primed ready for painting. Please pay attention to the painting instructions provided.

General

The OETTINGER Front skirt replaces the standard front apron and is mounted using the standard fixing points.

1. Preparation for assembly

- Jack the vehicle up and make sure that it is secure.
- Remove the front wheels if necessary.
- Remove the front licence plate.
- Open the bonnet/hood.

2. Removing the front bumper

- Remove the Torx screws from the top of the grille (illustration 1).
- Release the splash guard from the bottom of the front spoiler lip, to do this remove all the Torx screws.
- Remove the upper front wheel arch liners by unscrewing the Torx screws.
- Then release the lower front wheel arch liners, again by removing the Torx screws securing the liners.
- Unscrew 1 Hexagon head screw from inside each wheel well as shown in illustration 2.
- Remove 2 Torx screws either side from the side guide brackets as shown in illustration 3.
- Disconnect the wires from the fog lamps.
- Unclip the fog lamp surrounds either side and remove the fog lamps (3 screws for each lamp).
- Pull off the hose for the headlamp washers from the reservoir and plug the connector on the reservoir.
- Remove the standard cover for the towing eye.
- Carefully unclip the bumper from the guide brackets and wing/fender either side and release from the bonnet/hood latch and pull off the vehicle.

3. Preparing the OETTINGER front apron for fitting

- Fix the two fog lamp surrounds using 4.8 x 10 mm screws (illustration 4).
Important: make sure that the grille mesh is to be mounted with the correct side facing outwards before fitting (see illustration 5).
- Fit the mesh over the outer openings using 4.8x10 mm screws.
- Trim excess mesh (see illustration 6) especially around the fog lamp surrounds.
- Fix the front brackets for the fog lamps with two 4.8x16 mm screws each side (see illustration 7).
- Insert the fog lamps and lightly fix in place using two machine screws, mount the washers and nuts only loosely at first (illustration 8 + 9).
- Mount the rear brackets loosely using one 4.8x16 (illustration 10) and loosely attach to the lamps to the brackets with machine screws, washers and nuts.
- Adjust the fog lamps and tighten the screws, the lamps must align with the mesh!
- Transfer the headlamp washers. Attach the washer jets using the hardware provided (illustration 11). Route the hose under the grilles and fix using wire ties.
- Position the OETTINGER front apron centrally on the vehicle and push carefully in place and clip either side into the wing/fender. Check the alignment and fit.
- Mark the position through the opening for the standard fixing point in the wheel arch left and right on the OETTINGER front apron. Remove the apron and drill a 6.5 mm (1/4") hole in the apron in the positions marked (illustration 12 + 13). Fit the speed fasteners from the standard apron over the holes.
- Position either the OETTINGER or standard grille inserts in the OETTINGER front apron and fix using the screws provided (illustration 14).

4. Fitting the OETTINGER carbon splitter, Order No. OE 804 273 00

- Mark the position of the slits for the splitter either side under the edge (illustration 15 + 16) and then cut them out. Note: keep the slits as small as possible – do NOT sever the apron at the back!!!
- Slide the carbon lip in the openings with the rounded edge facing forwards. Position the splitter as required and fix in place using sufficient adhesive.

5. Remounting the front bumper

- Carefully push the bumper onto the guide brackets and clip it into the wings/fenders. Check that the gaps and fit before fixing in position.
- Mount the bumper in reverse order as described in section 2.
- Fix the air vents in the under body to the OETTINGER front apron by pushing them carefully down.
- Reaffix the lower wheel arch liners to the OETTINGER apron (illustration 17)

Illustration of the OETTINGER front apron for the Audi A3 Sportback / Audi A3 (8P) 3 dr. facelift

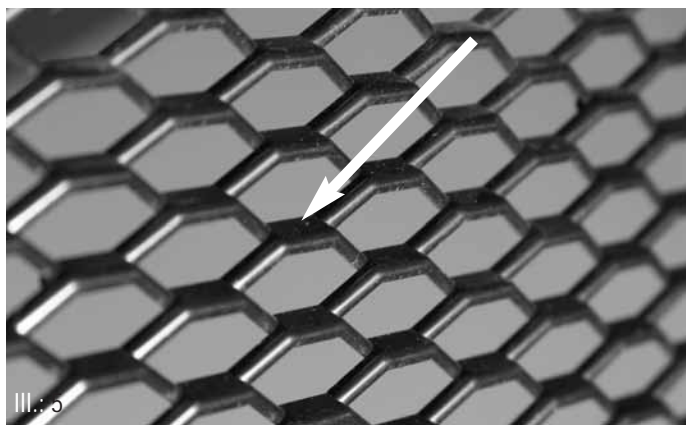
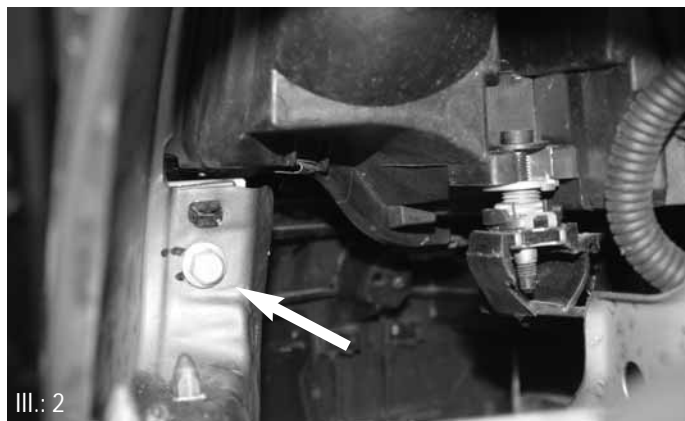


Illustration of the OETTINGER front apron for the Audi A3 Sportback / Audi A3 (8P) 3 dr. facelift

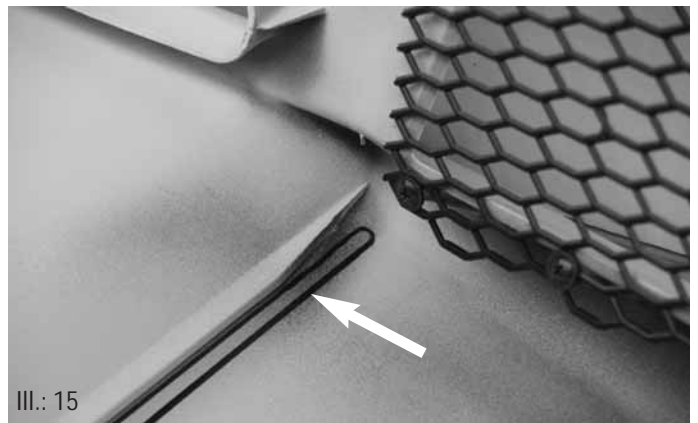
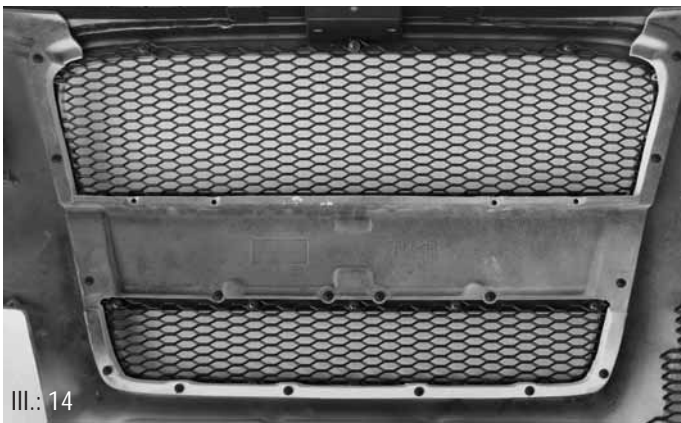
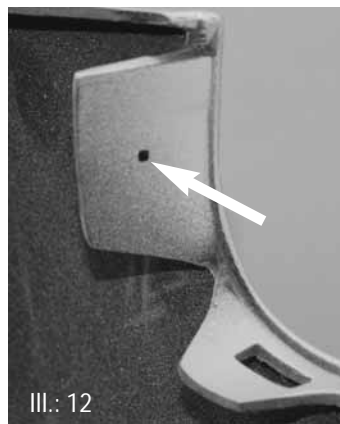
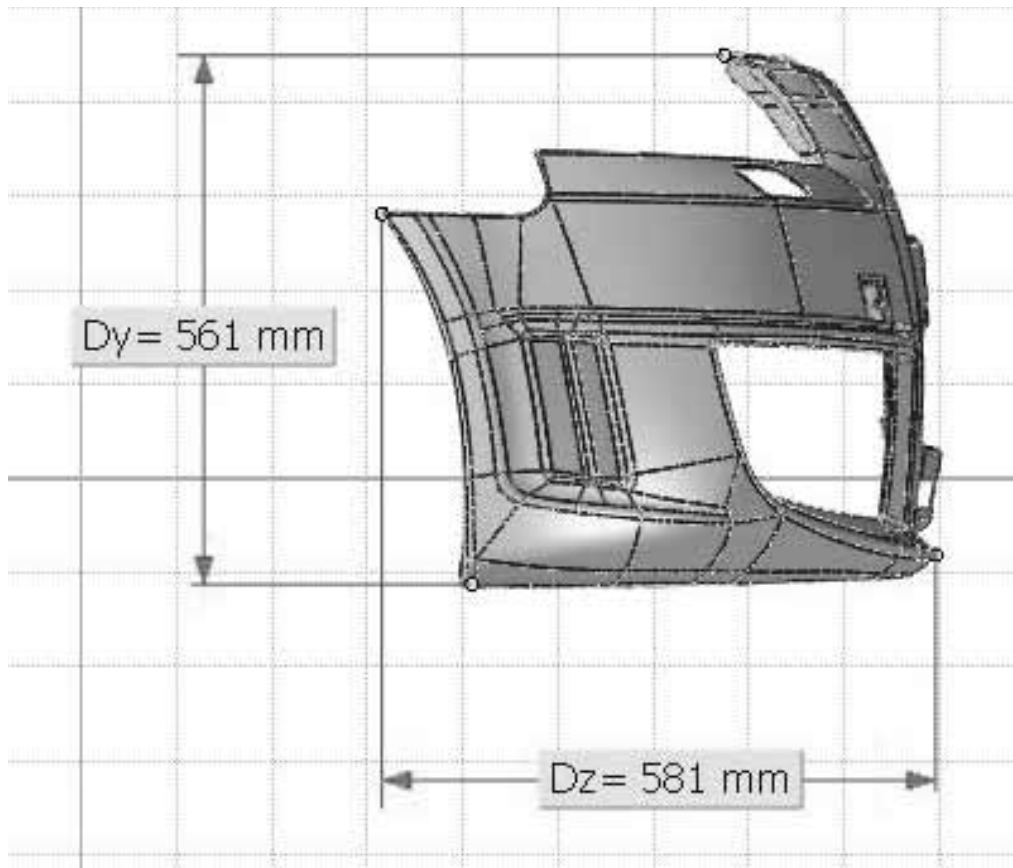
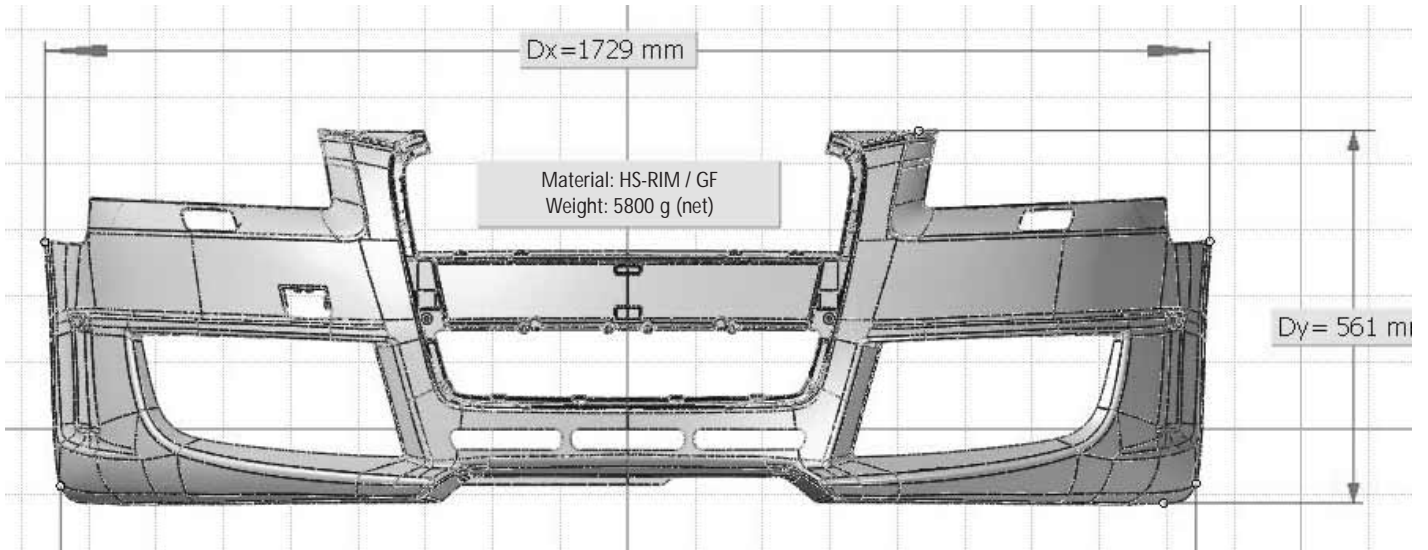


Illustration of the OETTINGER front apron for the Audi A3 Sportback / Audi A3 (8P) 3 dr. facelift



Abbildungen OETTINGER-Frontschürze A3 Sportback / Audi A3 (8P) 3-Türer mit Facelift



OETTINGER side skirts (set) for Audi A3 Sportback

Order No: OE 804 284 00

Note

The OETTINGER side skirts are manufactured from high quality material for an accurate fit and are primed ready painted. In order to ensure the best fit, it is recommended to carry out a trial fitting before painting. Please pay attention to the painting instructions and the drying time for the adhesive.

General

The OETTINGER side skirts are glued on the standard sills below the doors and fixed using existing fixing points in the front and rear wheel arches.

1. Preparation for assembly

- Jack the vehicle up and make sure that it is secure.
- Remove the front and rear wheels
- Remove the front trim strips, to do this unscrew the Torx screw in the inner wing/fender and pull off the trim strip (illustration 1). Remove any glue residue and clean the surface.
- Remove the rear trim strips, to do this pull the trim strip off. Remove any glue residue and clear the surface.
- Before painting, check the fit of the OETTINGER side skirts in the area around the rear doors (illustration 2), make sure there is no interference when opening and closing the doors. Rework the OETTINGER side skirts and/or adjust the trim on the door if necessary.

2. Fitting the OETTINGER side skirts

- Apply a 4 mm (5/32") wide bead of adhesive in the groove on the reverse side of each painted OETTINGER side skirt (illustration 3). Prior to applying the adhesive ensure that the groove is free of paint by lightly sanding the surface.
- Together with a second person! Push the side skirts into the front and rear mounting openings of the front trim strips which have been previously removed. Secure the side skirts along their whole length using adhesive tape.
- Fix the side skirts in the front wheel arches using the standard Torx screws (illustration 4)
- At the rear the skirts are only glued (illustration 2).
- Check the alignment and fit of the skirts (illustration 5), push firmly in position again. Tighten the fixing screws and remove any excess adhesive. Check and reapply the adhesive tape if necessary.

Illustration of the OETTINGER side skirts (set) for Audi A3 Sportback

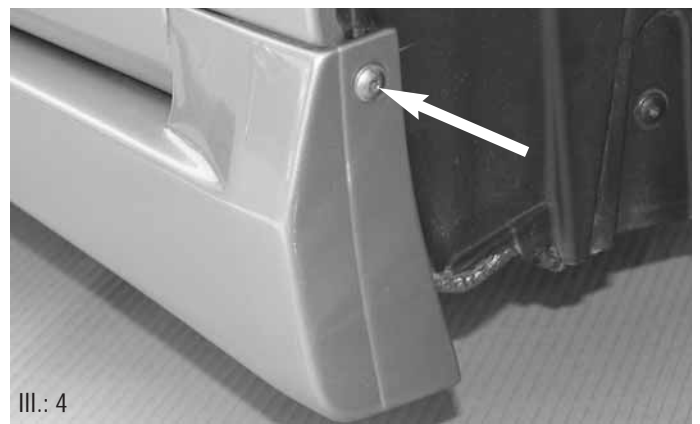
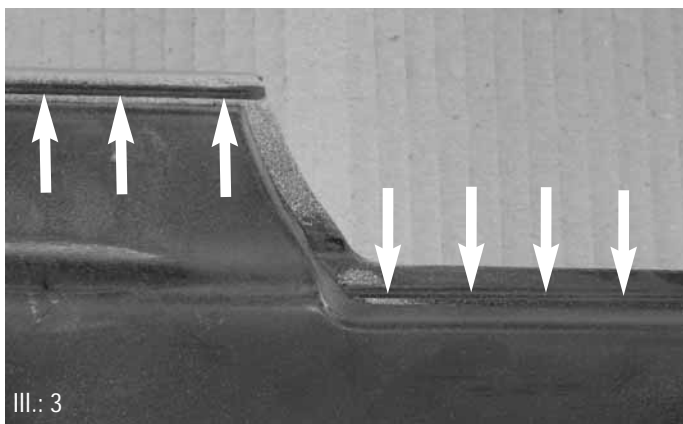
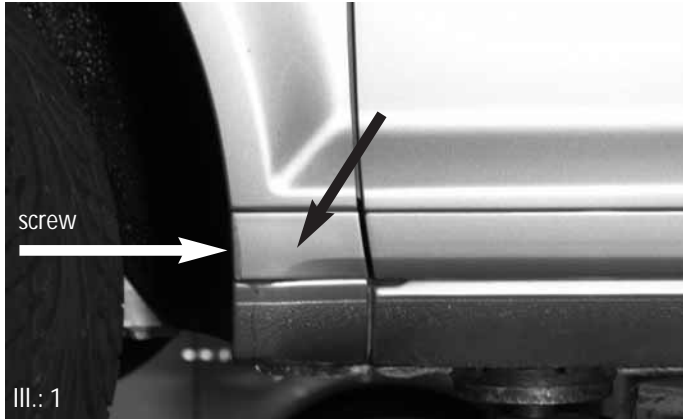


Illustration of the OETTINGER side skirts (set) for Audi A3 Sportback

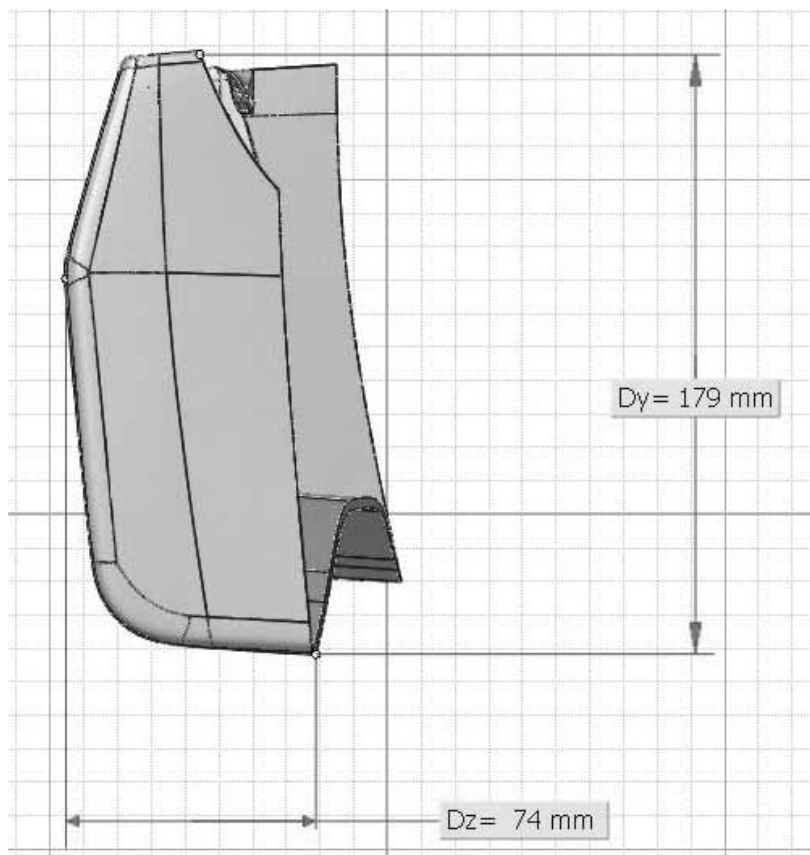
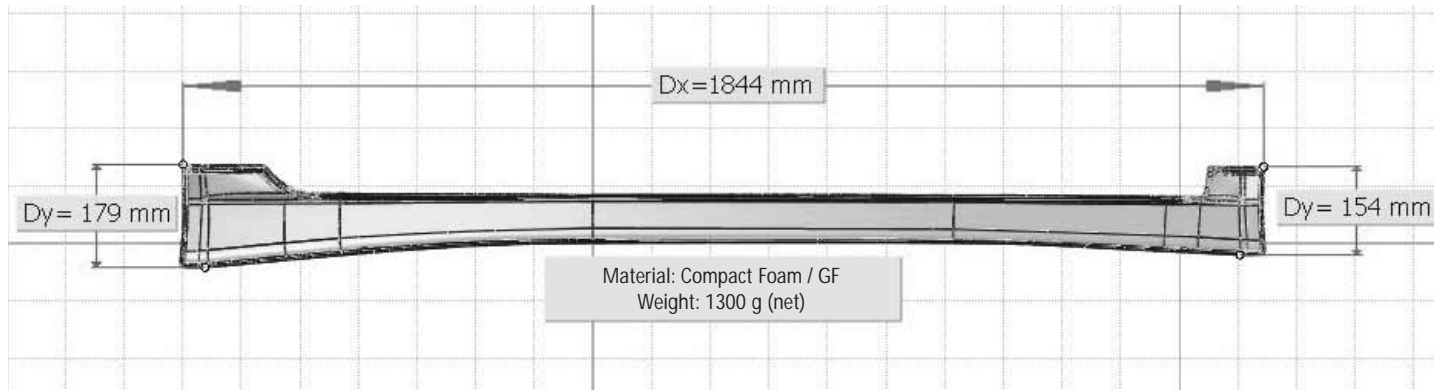


Illustration of the OETTINGER side skirts (set) for Audi A3 Sportback



OETTINGER rear skirt for the Audi A3 Sportback

Order No: OE 804 285 00 (twin tail pipe) and OE 804 286 00 (4 tail pipe)

Note

The OETTINGER rear skirt is manufactured from high quality material for an accurate fit and is primed ready painted. In order to ensure the best fit, it is recommended to carry out a trial fitting before painting. Please pay attention to the painting instructions.

General

The OETTINGER rear skirt replaces the lower part of the standard rear apron. It clips into the standard fixing points and is fixed in the wheel arches using the standard screws.

1. Removing the standard rear skirt

- Jack the vehicle up and make sure that it is secure.
- Remove the rear wheels
- Release the wheel arch liners from the standard lower part of the rear bumper by unscrewing the screws in the wheel arch liners. Remove the screw behind the liner (illustration 1) from the speed fastener.
- Unscrew the 2 screws in the under surface of the standard lower part of the rear bumper from the brackets.
- Now remove the lower part of the rear apron by unclipping it.

2. Fitting the OETTINGER rear skirt

- Beginning at the back in the middle, push the painted OETTINGER rear skirt on the rear bumper and clip in place. Check the alignment.
- Align the OETTINGER rear skirt with the edge of the wheel arches and fix using the standard screw which is inserted behind the wheel arch liners (illustration 1).
- Affix the wheel arch liners using the standard screws.
- Clip the painted cover for the towing eye (illustration 2).
- Insert the alu. bracket supplied (illustration 3) in the rear skirt and fix in place using the standard screws (illustration 4).
- Stow the extension for the towing eye (illustration 5) in the spare wheel recess together with the standard towing eye.

Note: It is possible to retro fit the OETTINGER 4 tail pipe rear exhaust silencer (illustration 6).

Illustration of the OETTINGER rear skirt for the Audi A3 Sportback

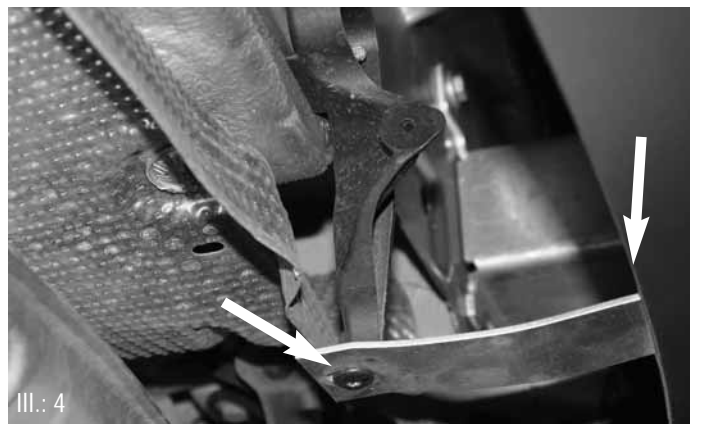
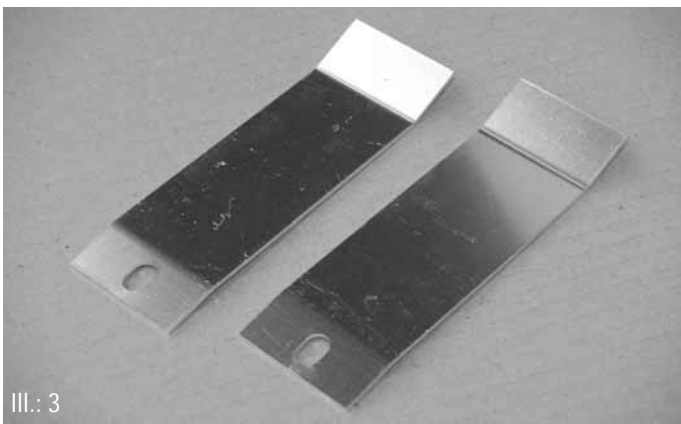
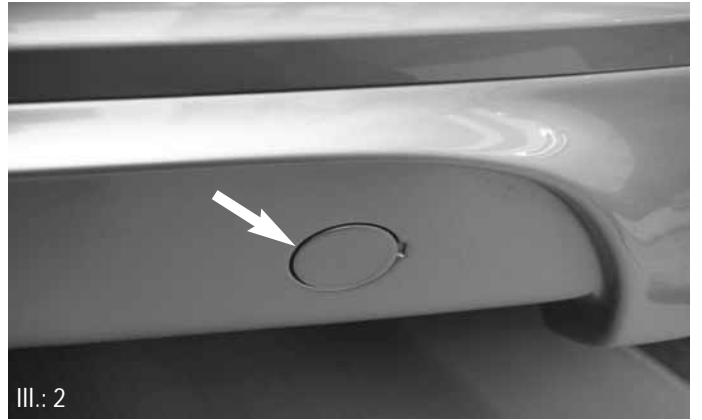
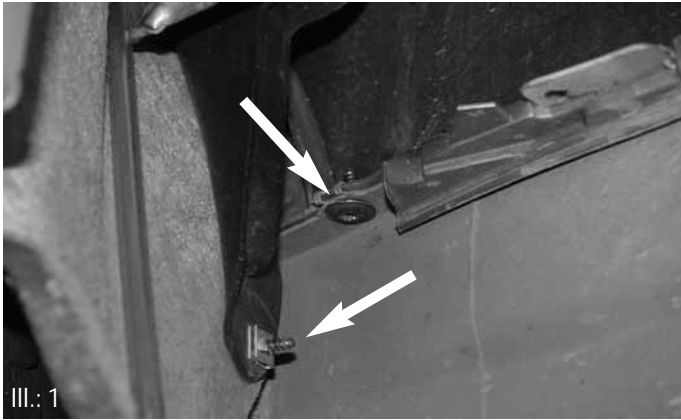


Illustration of the OETTINGER rear skirt for the Audi A3 Sportback

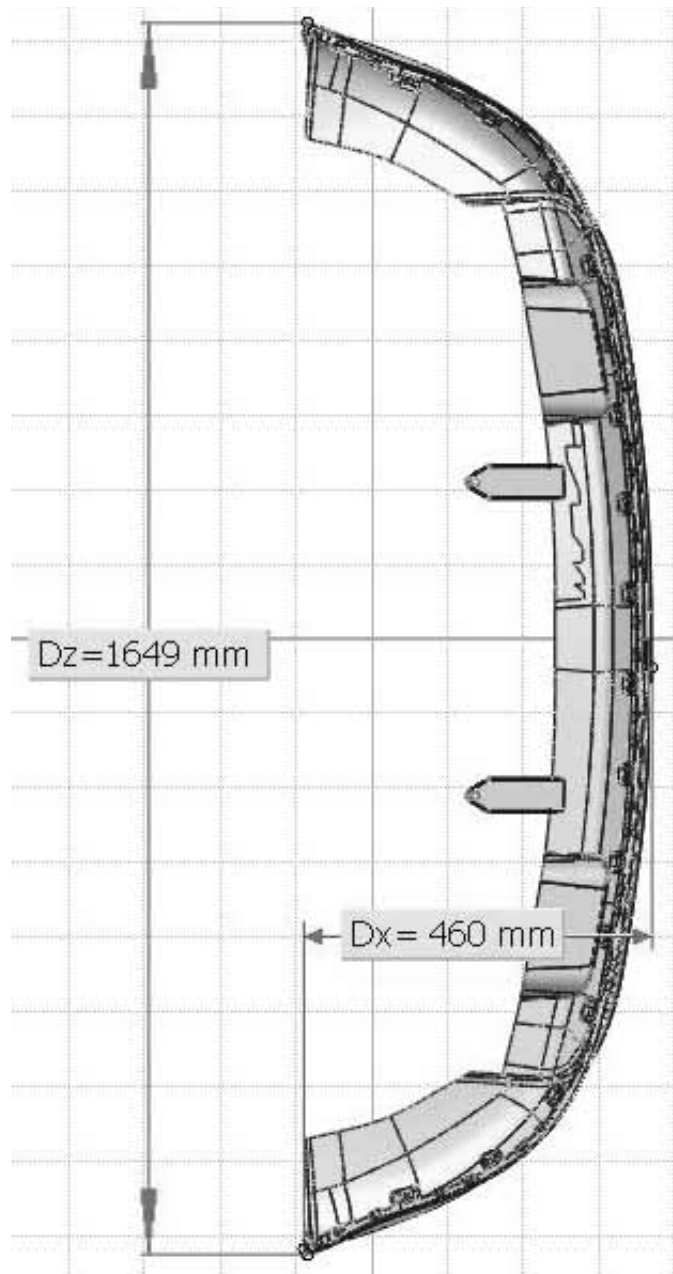
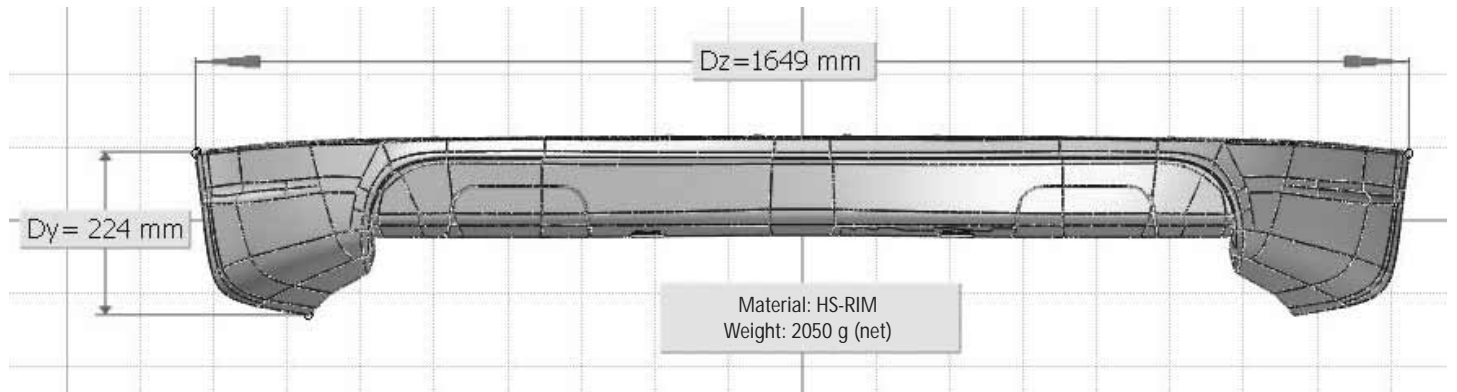


Illustration of the OETTINGER rear skirt for the Audi A3 Sportback



OETTINGER rear roof spoiler for the Audi A3 Sportback

Order No: OE 804 287 00

Note

The OETTINGER roof spoiler is manufactured from high quality material for an accurate fit and is primed ready painting. In order to ensure the best fit, it is recommended to carry out a trial fitting before painting. Please pay attention to the painting instructions and the guide for gluing body parts and spoilers as well as the drying time for the adhesive.

General

The OETTINGER rear spoiler is glued to the standard rear roof spoiler.

1. Preparation

- Position the unpainted OETTINGER roof spoiler centrally on the standard rear spoiler. Push on firmly and check the fit and alignment (illustration 1a + 1b).

2. Fitting the OETTINGER rear roof spoiler

- Apply sufficient adhesive on the degreased contact surface of the painted OETTINGER roof spoiler (illustration 1c).
- Position OETTINGER roof spoiler centrally over the standard roof spoiler and then push on firmly (illustration 1a, 1b + 1d).
- Secure the OETTINGER roof spoiler along the complete width with adhesive tape.
- Wipe away any excess adhesive. Check and reapply the adhesive tape if necessary.

Illustration of the OETTINGER rear roof spoiler for the Audi A3 Sportback

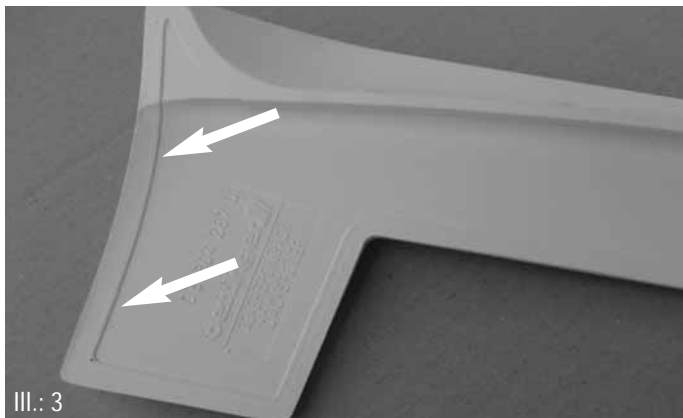


Illustration of the OETTINGER rear roof spoiler for the Audi A3 Sportback

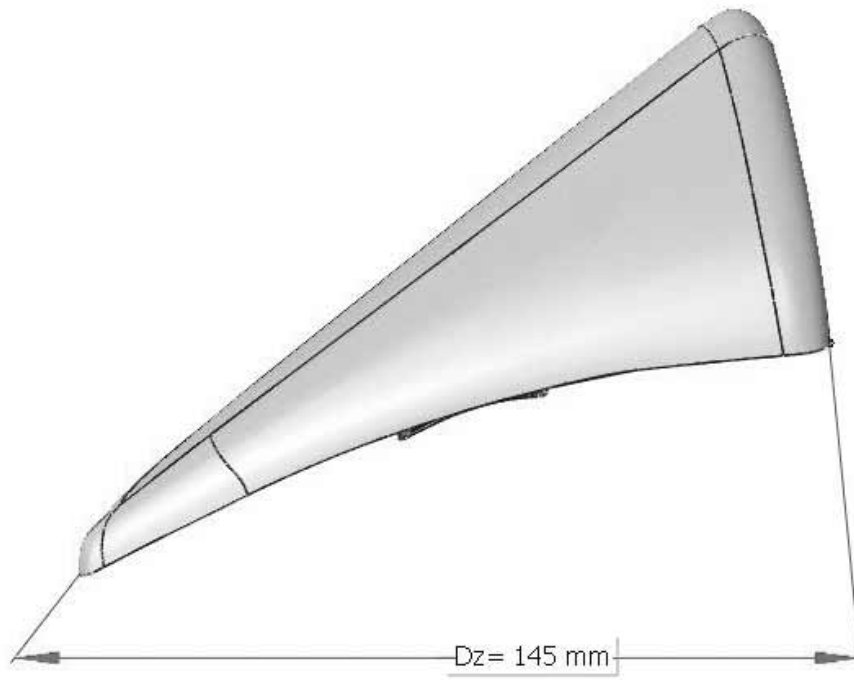
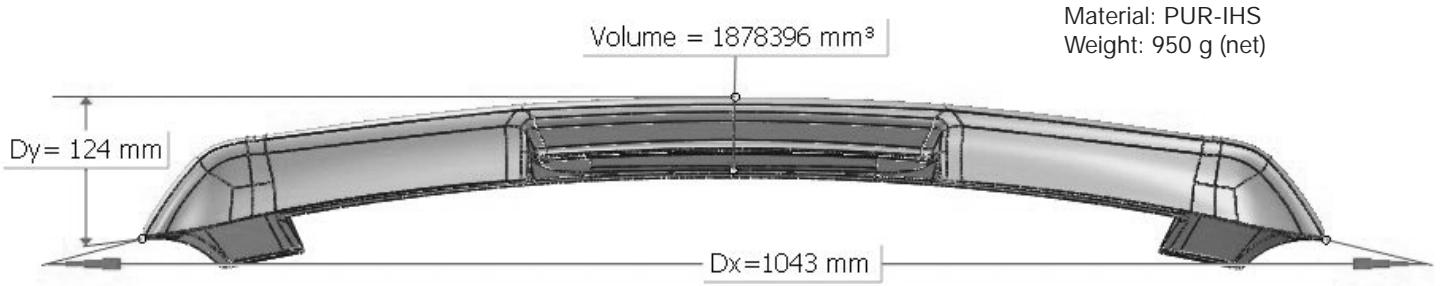


Illustration of the OETTINGER rear roof spoiler for the Audi A3 Sportback



Guidelines for painting OETTINGER auto body parts

A visual improvement of the parts and of the vehicle as a whole is achieved by painting the parts after trial fitting.

Priming represents the first step when treating the surface. Additional steps such as sanding, cleaning, and filling are still to be completed.

For the finishing coat, we recommend following the guidelines provided to you by your paint supplier.

We would like to point out that PUR parts are made from a self skinning foam and may therefore have pores on the outer surface. These have to be repaired by appropriate means, e. g., by filling and priming.

For a surface cleaner, we recommend using the plastics cleaner No. 85-81 from Spies-Hecker.

In order to avoid deformation of the parts due to material shrinkage, we recommend painting the parts off the vehicle and drying them at max. 35-40 °C.

Follow these steps when painting:

Support the parts in a similar position to that which they are to be mounted on the vehicle. Don't allow the parts to bend, sag, or deform during painting and drying. Deposit the parts carefully, otherwise you will encounter problems when mounting them, e. g., corrugation and tensions in the part.

Preparing for the finishing coat:

Clean the part with plastics cleaner.

Sand the part with sandpaper (grain 600).

Remove all dust from the part.

If necessary, fill in any pores in the surface and wet-sand the part.

Clean the part with silicone remover.

Check the part and fix faults if necessary.

Finishing Coat: Solid Paint

- Mix 2 pack acrylic paint with 30 % elasticiser.
- Add to this mixture, 2 to 1 parts by volume, the 2 pack hardener and then add thinners if necessary.

Finishing Coat: Metallic Two-Layer Paint

Finishing coat using metallic two-layer paint

- Paint 1st layer with metallic base coat.
- For 2nd layer, mix 30 % elasticiser with the 2 pack clear coat.
- Add to this mixture, 2 to 1 parts by volume, the 2 pack hardener and then add thinners if necessary.

Caution:

Never dry parts at more than 35-40 °C. During painting and drying all parts must be set down fully supported in order to avoid deformation. Do not cover up the part number with paint.

Notes:

We recommend marking the inside of the painted part with the VIN to ease identification in the case of theft.